



White Paper

AC & DC Power Protection at Communication Sites

AC & DC Power Protection For Communication Sites

The incidence of damage to equipment in general is higher from power line surges than by any other I/O port. This is not to say more energy comes through the power line, just that the damage is more visible there. Since the coax connection to the tower is the source of the largest surge current in the building, power line port damage is usually due to improper grounding techniques and lack of surge protection devices. There are two probable ways power line caused equipment damage occurs.

Power Line Strikes

Surge current may be imposed on a power line by a lightning strike near the equipment or on an overhead utility line. Current may directly enter buried lines when lightning strikes a street light or may be conducted to a buried power line if lightning strikes near the line. Whichever way the surge current enters, it causes a bi-directional flow of surge current on the power line. Current flows both toward the equipment building and away from it, toward the nearest distribution transformer.

When the surge current flowing toward the equipment building reaches a distribution transformer, part of the energy is diverted to ground. Energy not diverted to ground is coupled through the transformer by arcing (noncatastrophic) or capacitive coupling. Surge current continues toward the equipment building on both the “neutral” and “hot” conductors of the power line.

At the building’s main power line entrance panel the neutral is tied to ground, reducing neutral conductor energy. Most of the energy from the lightning strike should remain on the “hot conductors”.

Since lightning is short in duration (20–350 microseconds) compared to 50/60 Hz fundamental ac frequency, the surge current may either take the form of a mostly positive ringing waveform, a mostly negative ringing waveform, or a combination of the two. It isn’t possible to state which is more likely at any given instance because the impedances along the path would have to be defined. These impedances include the surge impedance, the load impedance and the line impedance.

- Surge source impedance differs on directly struck power lines and with nearby strikes. The impedance changes as the surge current is conducted by arcing or capacitive coupling at one or more transformers between the strike and the building. The surge impedance also depends upon the impedance of each ground connection along the path, including the transformers and the point at which the power line enters the equipment building.
- Load impedance depends upon the amount of load inductance (power factor) placed across the line by devices such as air conditioners, heaters and lights.
- Line impedance is governed by the length and number of lines, and the line resistance and transformer impedance.

Impedance values for each of these elements are independent variables representing an infinite number of possibilities.

Because the surge, load, and line impedances cannot be easily defined, the lightning-caused voltage wave shapes are difficult to predict. Nevertheless, some standards have been developed to provide guidelines for possible values of surge voltages and currents induced into the power lines by the lightning discharge.

Even though the peak values of lightning-induced voltages and currents are important, the wave shape they take (i.e., rise time and duration) are critical to determine the total amount of energy in the lightning discharge.

One Standard that has been formulated is designated ANSI C62.41 - 1991. This standard defines voltages/ current waveforms and location categories for given surge exposures (Figure 1).

Demarcation between Location Categories B and C is arbitrarily taken to be at the meter or at the mains disconnect. (ANSI/NFPA 70-1990(2), Article 230-70) for low-voltage service, or at the secondary of the service transformer if the service is provided to the user at a higher voltage.

(Figure 2)

- Category A is for “long branch” circuits such as long run secondary ac wall outlets. Its surge wave is a 6kV open circuit voltage, and 200A short circuit ringing waveform (damped cosine) with 0.5ms rise time and a frequency of 100kHz
- Category B is for major feeders, short branch circuits, and receptacles located near an indoor main distribution panel. There are two wave shapes designated to a category B location:

(1) 100 kHz Ringing Wave - A 6kV open circuit voltage and 500 Amp short circuit ringing wave with a 0.5ms rise time and a frequency of 100kHz (Figure 2).

(2) Combination Wave – A wave combining a 6kV, 1.2/50ms open circuit voltage, and a 3kA, 8/20ms short circuit current (Figure 3 & 4).

- Category C is for outdoor overhead lines and service entrances. The waveform is the same as a category B combination wave, however the currents and voltages are higher (6kV at 3kA, 10kV at 5kA, and 20kV at 10kA). The current values are derived from the surge generator impedance, and the surged load impedance.

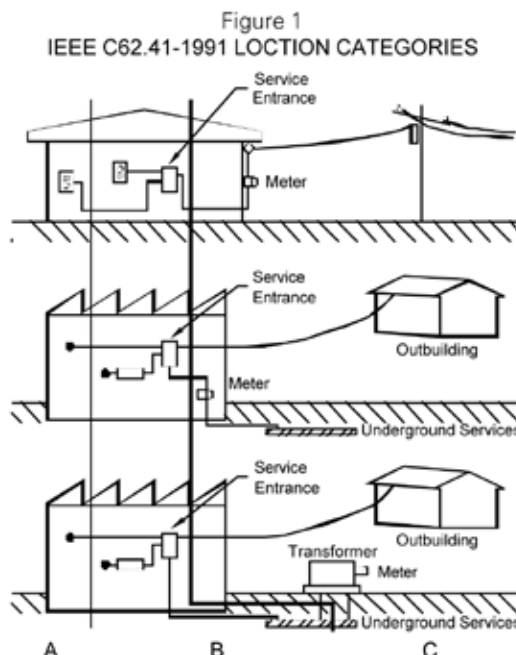

- A - Outlets and long branch circuits;
All outlets > 10m from B
All outlets > 20m from C
- B - Feeders and short branch circuits;
Distribution panel devices.
Bus and feeders industrial plants.
Heavy appliance outlets with “short” connection to service entrance.
Lighting systems in large buildings.
- C - Outside and service entrance;
Service drop from pole to building.
Run between meter and panel.
Overhead line to Outbuilding.
Underground line to well pump.

Demarcation between Location Categories B and C is arbitrarily taken to be at the meter or at the mains disconnect. (ANSI/NFPA 70-1990(2), Article 230-70) for low-voltage service, or at the secondary of the service transformer if the service is provided to the user at a higher voltage.

A 6kV 100kHz 200A & 500A ringing waveform:

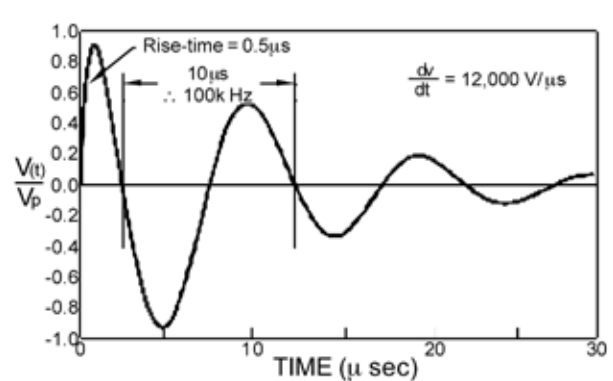

100 kHz Ring Wave (Figure 2)

Tower Strikes

Surge current may also arrive to stress equipment within the building with a strike to the communication tower. In an ideal installation, the tower, bulkhead, equipment and utility grounds are all tied together with a single point ground. Just as it is impossible to define the power line surge waveforms accurately because many independent variables are involved, it is also difficult to predict exactly how much stress will be delivered to the power line circuits when lightning strikes the tower. The tower lighting circuit is a surge producer often overlooked. Protectors are available to prevent this incoming surge energy from transferring to the building's power lines.

Approximations can be used to help predict the amount of stress expected for a single point ground system. If radial wires are installed with Ufer grounds at the tower base and connected to the guy anchors, surge current at the tower base is divided by the number of radials. A short radial (only one) should connect the tower base to the below grade perimeter ground.

The perimeter ground encircling the equipment building should connect to the bulkhead and not to any radials. The utility ground should connect to the perimeter ground. With this interconnection scheme, as indicated in previous chapters, it should be faster for the surge to propagate via the perimeter than it is to traverse through the building. If this isn't the case, major power supply stress may occur.

Surge current coming from lightning that strikes a power line some distance from the building may be divided several times as it flows through transformers and other devices, but it is important to design protection for the "worst case." Where lightning strikes the low voltage secondary conductors connected to the meter and main breaker, the current is divided. Current flows toward the building and also back towards the distribution transformer. Surge current flowing towards the building may be in the order of 10kA or more. A power mains protector is needed to protect the distribution panel and connected equipment. Protectors must be able to withstand line current surges greater than those specified by the IEEE/ANSI standards.

The one way to theoretically limit stress on the equipment's power supplies is to provide additional inductance (isolation) for the power line path inside the equipment building. Higher inside inductance forces more surge current towards the outside perimeter ground path. Additional inductance can be made

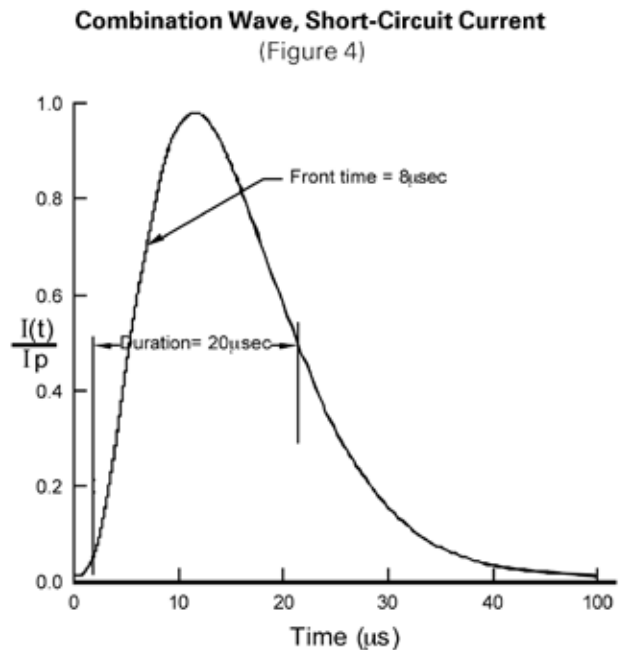
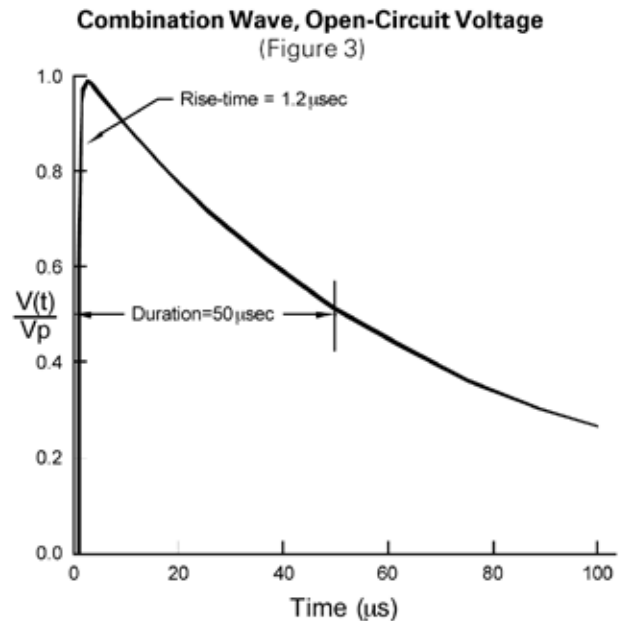

[GRAPHS FROM IEEE - ANSI C62.41 - 1991]

by placing the lines in EMT conduit, using long power cords to the equipment or winding coils in the power cord. (Remember, like coax coils, there is a limit to the voltage isolation achievable before breakdown.)

One possibility for damage remains in spite of this precaution. The phase conductor for the 60Hz power may be at a voltage peak when the surge occurs, causing a breakdown. For critical applications, an additional power line protector is recommended at the equipment rack.

An outlet strip type protector, that plugs into a wall socket (the type often advertised in connection with computer/consumer equipment), may not protect the equipment because it is “grounded” at the plug socket not the single point ground. The plug socket safety ground wire is “in the middle” of two inductances (the power cord inductance from the equipment, and the safety wire inductance running back to the breaker box and power company ground rod) and is effectively removed from earth ground by the series inductance of the ground wire. The actual current an “outlet strip” type protector will conduct to earth ground during a strike is limited by the series inductance of the safety wire path and will rarely conduct current flow close to advertised ratings. There will be a peak voltage differential between the safety ground and the bulkhead single point ground during a lightning strike. The differential could be several kilovolts and cause damage to equipment in this current path.

For applications where there are no other ground paths and the ac safety ground is the only ground available, this ground must be used. Be aware of possible outbound current flow to lower potentials through other safety ground “protected” equipment I/Os.

Protective Components

There are many books now on the market which address the design of components utilized in surge protectors. Most protectors use one or more of the following components:

- Air gaps
- Gas tubes
- Metal Oxide Varsitors (MOV)
- Silicon Avalanche Diodes (SAD)
- Four-layer semiconductors
- SCR's

Air gaps handle high currents, but are slow to act and require regular inspection. Altitude, temperature, humidity, pollution, corrosion, shape and spacing all effect air gap performance.

Gas tubes are better than air gaps, but both share the problem of “follow-on” current. When surge current occurs during the instant that 60Hz ac is at a zero potential, follow-on current is not a problem. If the surge arrives at any other time, triggering an arc, the arc could be sustained by the power from the 60Hz source. The arc extinguishes when the waveform voltage falls below the arcing voltage. This voltage can be even lower if radioactive isotopes are used inside the gas tube. The US military now requires all gas tubes be non-radioactive.

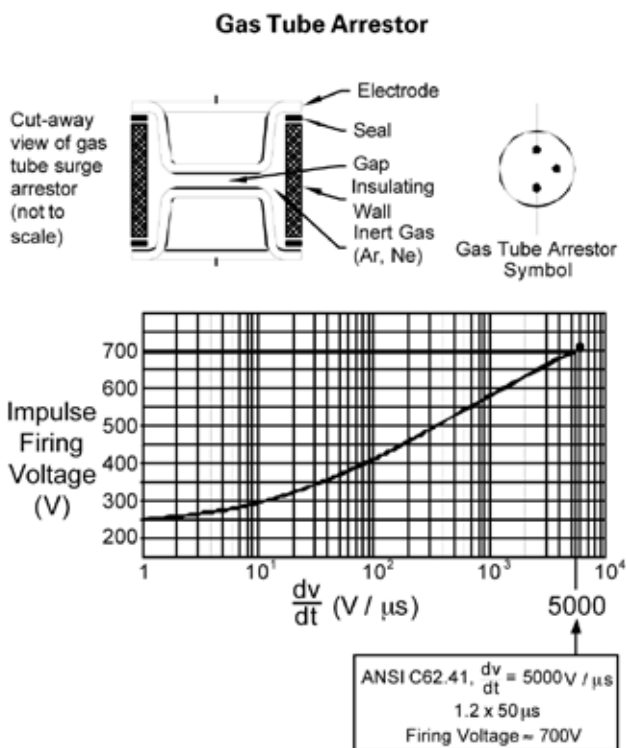

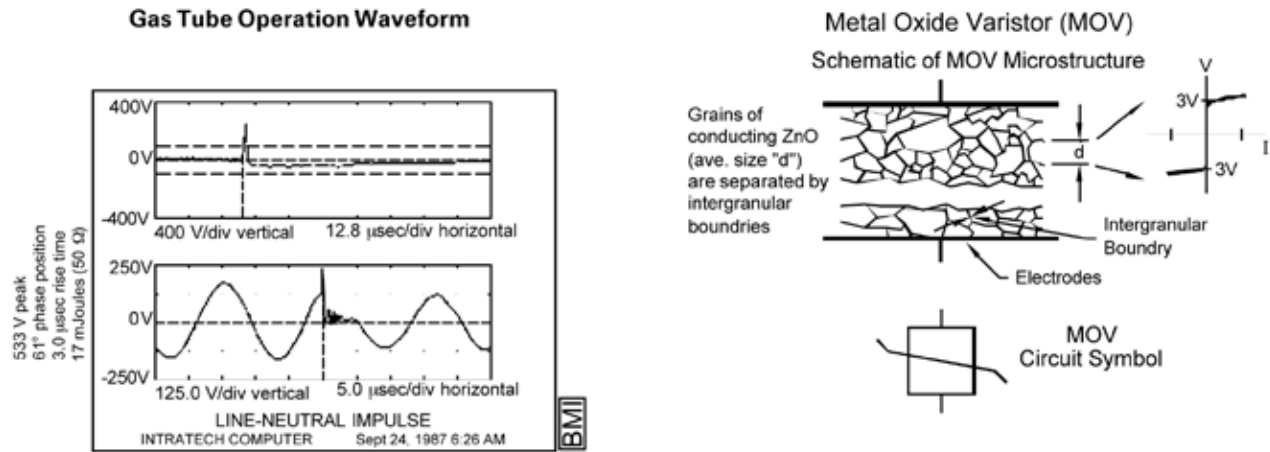

A power loss of up to 1/2 cycle (8.3ms) can result from a gas tube turn on that may cause problems with sensitive equipment. The air gap and gas tube are much like Silicon-Controlled Rectifiers (SCR); once in a conducting mode, the voltage to it must be almost completely removed to open the circuit again.

There is another dilemma with air gaps and gas tubes. As they “crowbar,” the dv/dt created is high in harmonic energy and can be coupled capacitively through power supply transformers causing problems in sensitive circuitry.

The **metal oxide varistor (MOV)** does not “crowbar,” it “clips” or “clamps,” starting at a given turn-on voltage. MOVs handle moderate amounts of surge current and have a finite lifetime. The devices are made from zinc oxide granules. As the voltage across it rises above turn-on, electrons tunnel through and conduction occurs. The granules heat and melt together. Melted granules cannot reunite to form zinc oxide. In the end, the MOV is mostly zinc and short circuits. With heavy usage, the MOV life is shortened.

Surge currents conducted by the MOV create a voltage drop through the MOV. As current increases, the voltage drop rises. The action is nonlinear and is often referred to as the “clamping ratio.” In an ideal situation, the voltage would remain the same regardless of current.

High pulse current diodes (also known as **silicone avalanche diodes, SADs**) come in a variety of configurations. They have a more ideal clamping ratio than MOVs with a faster response time to the surge wave-front. Their lifetime is unlimited if surge currents remain within specified current handling ranges. Unfortunately, SADs do not handle much surge current in a single component package. Special consideration must be given to SAD surge protection device design to insure necessary power handling capability. SADs and MOVs still act much faster than air gaps and even most gas tubes.

The SAD’s and MOV’s speed is due partially to their high capacitance. Surge current charges the capacitance, making the effective response time of a leadless MOV less than a nanosecond. A large pulse-handling SAD may have high capacitance. A leadless chip SAD reacts in picoseconds.

SADs and MOVs are rarely used without leads, even though leads add inductance. Leads must be connected to these devices when they are used in a protector. Protectors using either SAD or MOV components are often advertised as having sub-nanosecond response times. To accomplish this, they must use lowpass filtering to offset the inductive lag, insuring a quick response. Power line protectors advertised as having sub-nanosecond response time have misleading specifications if they do not

have lowpass filtering or leadless design and installation. Filtering is important to prevent small spikes, surges and noise. Although the voltage excursion of such spikes, surges and noise may not be hazardous, it may cause equipment problems.

Another device listed is a four-layer semiconductor. It is a “follower” or “negative resistance” device, much like the SCR. It handles more current than a SAD of the same size because of its crowbar action and unlike the SCR, it has a “turn-off” voltage.

Four-layer semiconductor protection devices are not limited to power line applications. They may also be used on telephone or control lines, alone or in complex combinations (hybrids).

The last device on the list which could be applied in a protection circuit is the SCR (Silicon Controlled Rectifier). This device comes in a variety of sizes and could be very fast when teamed up with an SAD or MOV. The SAD/MOV provides the speed and the SCR protects the SAD/MOV from long duration surges. In power main applications, the SCR’s dv/dt problems could be buffered by the capacitance of the SAD/MOV and any filtering that is present.

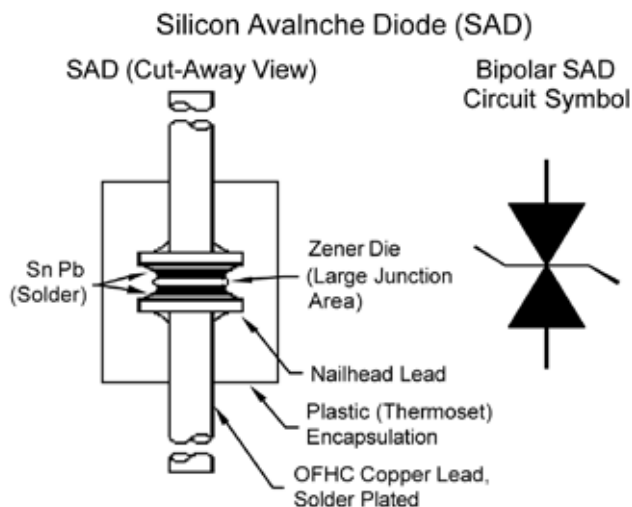

AC Main Power Protector Types

Parallel or Shunt Type Protector. The shunt type ac protector is the most common protector circuit in use today. It can be a simple MOV from each lead to the safety ground, matched MOVs or SADs in a differential and/or common mode, or a hybrid circuit of cascading components for fast turn-on and high surge current capability. The shunt type protector is not load dependent and must be located close to the entrance panel to reduce propagation delays. A 10kA rated protector in a typical installation will rarely conduct anything close to its current rating except during a direct strike to the secondary drop at the entrance panel. The amount of current the protector will conduct to ground depends on the equipment load impedance, the inductance of the ground conductor on its way to earth ground, and the fall of potential resistance/impedance of the earth ground system.

Series In-Line Type Protector. An In-Line ac power protector consists of a pair of protective devices or hybrid circuits per phase, connected line to ground, one on each end of a load bearing air wound (air will not saturate) series inductor. There should be a circuit breaker or fuse in series with each non-linear device or hybrid circuit that opens in the event of a failure of the suppressor stage (they usually fail shorted), allowing power to continue to flow to the load. If a protective device fails, the associated circuit breaker opens and could activate an alarm circuit. There could be fixed capacitors in parallel with the intrinsic capacitance of the protective device(s) forming, with the series inductor, a Pi Network low pass filter. The additional capacitance absorbs some of the fast rise time energy as the device is turning on, and the low pass filtering provides EMI/RFI filtering to the protected lines. Turn-on time would not be an issue due to the “filtering action” of the circuit.

If there were two MOVs (for example) in each phase, separated by a series air wound inductor, the second MOV would be there to make a (nominal) current flow in the inductor creating a voltage drop. This drop limits the current to the equipment side MOV and allows the surge side MOV to take the brunt of the energy. The voltage across the surge side MOV will rise as increasing surge current goes through it (clamping ratio). The voltage difference between the surge MOV and the equipment MOV is the voltage drop through the coil ($E = Ldi/dt$). Since the equipment MOV is not seeing as much voltage, its current will be smaller. This is desirable since the voltage across the equipment MOV will be the same voltage applied to the protected equipment input. The life of the equipment MOV will be longer than the surge MOV. The same surge current limitations caused by inductive ground connections and/or ground system resistance/ impedance apply.

A shunt type or series type protector can conduct surge energy to their capacity only if attached to the site single point ground with a low inductance connection to a low resistance/impedance, fast transient response ground system.

Applying a single point ground protector retrofit to a site with coax entry on one wall and ac power on the opposite wall?

The ground connected to the ac power protector should be referenced to the single point ground. Assuming a tower strike, the inductive peak voltage drop across the current carrying ground leads (preferably copper strap) from the ground bar or bulkhead to earth would elevate the potential at the ground bar compared to the (lower) earth ground connection. The ground bar is directly connected to the equipment cabinet(s) through the coax cable shield(s).

All equipment ground connections should rise and fall in potential at the same time with no other paths (through equipment?) to a lower ground potential connecting point. If there are no other paths, and the potentials rise and fall together, there will be no current flow through the equipment.

If the protector and ground connection is on the opposite wall connected to a ground rod or ring, there could be damage from current flow from the elevated potential on the coax cable shields, through the equipment, back to the ac power ground on the opposite wall (that has not yet been elevated in potential) due to ground potential propagation delay around the ground ring. There could be an additional danger from the energy coupled to parallel or nearby conductors. The peak potentials could be additive and cause serious damage.

A protector mounted on the opposite wall next to the main ac entrance panel, and connected to the power company ground rod, would only protect from incoming energy on the secondary ac power conductors. Energy from a tower strike would elevate the equipment cabinet potential via the coax cable shields and current could flow from elevated rack/chassis ground returns up through power supply circuitry on its way to the outside world via the yet to be elevated ac secondary connection. The power supply could be destroyed. If a protector ground was connected to the (elevated) single point ground bar and true single point connections were maintained:

- The equipment protector reference ground would rise and fall with the master ground bar potential.
 - The ac power protector would protect the equipment power supplies from incoming energy on the ac power lines AND from direct or induced energy incoming from the coax cable(s) during a tower strike. One practical way to do a retrofit could be:
 - Remove any equipment rack or active electronic equipment circuit breakers from the existing distribution panel. Remove all wiring from the existing distribution panel to any equipment rack or active electronic equipment. Leave the existing shunt type ac protectors at their original location.
-

- Run a steel conduit, grounded at both ends, from the existing main distribution panel to a new sub-panel. Route new interconnection wiring through this conduit.
- Install a new sub panel next to the single point ground (MGB). Wire from the new sub panel, through a properly rated circuit breaker, directly to each rack or active electronic equipment.
- Connect a second shunt type ac protector to the hot leads and neutral in the new sub panel. Strap the protector case ground to the single point ground. For higher levels of protection and RF-EMI filtering, use an in line filtered ac protector. This device installs in series with the wiring from the existing distribution panel to the new sub panel.

If there is already ac power shunt type protection installed at the main ac input, leave it there. It will provide an extra measure of protection from an incoming strike on the secondary conductors.

AC Line Regulation

An ac line protector is not intended for power conditioning or over-voltage conditions. An ac line protector is specifically designed to protect equipment from short duration (nano/microseconds) high energy “spikes” caused by lightning events or other short term transient artifacts on the ac line. Extended surges and sags are handled with uninterruptable power supplies (UPS), and/or regulation transformers and/or brute filtering. Frequently, improved service grounding (earthing) can significantly improve “dirty” utility company power.

Communications Site Generators

All inside or outside generators must be connected to the perimeter ground. Both the neutral and the metal housing are to be grounded. All fuel tanks must be grounded, even if they are buried or tar coated (insulated). The location of the ac mains protector may be changed depending on the location of the generator and transfer switch.

Some generators hunt/vary their frequency or output voltage causing equipment problems. Protectors placed on the output or load side of the transfer switch will not remove long duration voltage peaks. They may be damaged or destroyed. Lightning protectors should be placed on the utility input side of the transfer switch.

Battery And Charger Protection

Some installations use batteries in combination with a charger to supply power to the equipment. The charger needs power line protection to survive a surge from a lightning strike.

Batteries that are in good condition provide substantial line-to-line capacitance, but they don't protect from common mode surges (lines to ground). If the batteries are located near the charger and the dc power lines to the equipment are long (inductive), a dc over-voltage protector may be needed at the equipment.

In non-screen room installations, long dc power lines will pick up the electromagnetic pulse of a nearby lightning strike. A capacitor bypass network can be used to shunt the pulse to ground. The network should have four parallel capacitors connected with very short leads. Values of 0.01 F, 0.1 F, 1 F, and 10 F are recommended. A high pulse current SAD may also be incorporated to clamp over voltages and reverse spikes from the equipment's dc power line. Be sure the turn-on voltage is high enough so the battery surface charge will not turn on the SAD. The SAD, like the MOV lightning protector, should not be used as a shunt type voltage regulator. EMP pickup can also be reduced by enclosing the dc lines in metal conduit. The conduit is grounded only at the equipment end.

Batteries should not use the earth ground bus in the equipment room as a means of providing a return circuit. Separate conductors for positive and negative connections should be run to each piece of equipment or equipment noise could be spread throughout the ground system.

Some manufacturers ground the negative (or positive) side of dc operated equipment to the chassis/rack. This reinforces the need for local dc over voltage protection since the chassis ground potential follows the rest of the ground system's potential during a lightning strike and could go up.

Stress could occur at the battery charger output because of the difference (inductive delay) in the positive and negative lead lengths and chassis ground. The problem can be solved by using and MOV/SAD devices at the charger output. The device's capacitance should be balanced (equal) to prevent hum pickup. They should be placed between each floating output and chassis ground.

The SAD/MOV device prevents an arc breakdown from occurring within the charger. Such a breakdown could damage components. Choose an SAD/MOV device rating high enough to allow the charger's maximum dc voltage to pass. Additional components could be installed at the equipment end to provide local protection.

Connections inside the equipment building should be free of paint and clean of all contaminants. Copper based joint compound is recommended. The connections should be tested when made as a preventive maintenance procedure.

At battery-operated sites, the ground connection may have dc current flowing through the joint under test and a negative resistance value may be displayed. Whether displayed or not, the DVM will need to measure the joint in both directions (reverse leads). The algebraic sum or the difference between the two readings, if both are the same polarity, will be the real ohmic value.

Solar Panels

At installations using solar-power photoelectric cells, the lines connecting them to the regulator can act as an antenna capturing the radiated surge fields of a lightning strike. Spike voltage line-to-line may be low because of the solar cell's impedance, but the surge voltage from each line to-ground may be quite high.

The high line-to-ground voltage could stress or cause premature failure of the series pass regulator. Any regulator failure means eventual outage for the equipment. SAD/MOV surge suppressor devices should be applied to limit transient voltages.

Never attach a lightning rod to a panel support, no matter how exposed a solar panel is to a direct lightning strike. The most effective way to protect solar panels is to use a lightning strike divertor placed a short distance away from the panel.

Please contact us for questions or further information on this topic.

Contact:

Tel: +1 (208) 635-6400

Email: sales@polyphaser.com

www.polyphaser.com
